

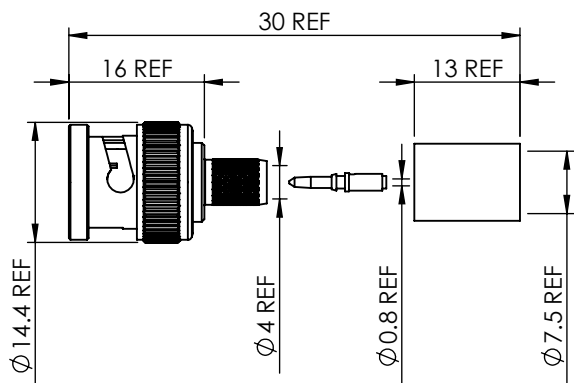

DO NOT SCALE DRAWING



Assembly Procedure : AP001

The assembly procedure is given on its own separate instruction sheet.
Please request the above AP number.

Stripping Dimensions

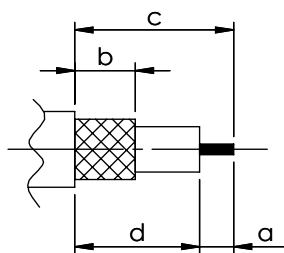

- a = 4.0 mm
- b = 8.0 mm
- c = 16.0 mm
- d = 12.0 mm

BNC STR. CR. PLUG 1505A QUAD (3 GHZ) 10-005-T36-EG

Suitable for Cables:

B1505A Quad Shield

Electrical Specification

- Impedance: 75 Ohm
- Frequency: 0 - 3 GHz (Cable Limited)
- Dielectric W/V: 1500 Veff
- Insulation res: 5000 M-Ohm

Mechanical Specification

- Centre contact retention
- Axial Force: 10 N min
- Cable Retention: 220 N min
- Mating cycles: 500
- Weight: 11.64 g

Environmental Specification

- Operating Temp: -55 to +155 Deg C.

Tooling

- Centre Contact: HEX 1.72 A/F
- Tool No: 336C2
- Crimp Sleeve: HEX 8.23 A/F
- Tool No: 336C2

7	WASHERS	SK5	NICKEL
6	OUTER BODY	BRASS	BL. NICKEL
5	GASKET	SILICONE	N/A
4	CRIMP SLEEVE	BRASS	NICKEL
3	INSULATOR	PTFE	N/A
2	CENTRE CONTACT	BRASS	GOLD
1	BODY	BRASS	NICKEL
ITEM	DESCRIPTION	MATERIAL	PLATING

A4	SHEET 1 OF 1	DIMENSIONS ARE IN MILLIMETERS			
REVISION :	A02		NAME	SIGNATURE	DATE
DRAWN :			GE		17/07/2009
ISSUE :	2		CHK'D	IG	21/07/2009
APPV'D					
6-8 COLNE ROAD, TWICKENHAM, MIDDLESEX. TW1 4JR					
<small>THE INFORMATION IS GIVEN AS AN INDICATION ONLY AND IS SUBJECT TO CHANGE WITHOUT NOTICE. IN THE CONTINUAL GOAL TO IMPROVE OUR PRODUCTS, WE RESERVE THE RIGHT TO MAKE ANY MODIFICATIONS NECESSARY WITHOUT PRIOR NOTICE.</small>					